



**Elevated Luxury Experience**  
**Cutting-Edge Performance Vinyl**  
**Versatile Style Integration**

## Luxury Style, Superior Performance.

The Zenith Series of Windows & Doors enhances any space with a lasting and bold modern aesthetic. Advanced materials and cutting-edge technology deliver exceptional performance and durability. Superior heat resistance, fade-resistant color formula, and premium sound insulation overcome climate limitations of traditional vinyl windows. The style and strength the of Zenith Series provide a new level of high-end design opportunities for residential and commercial projects.

**Elevated Luxury Experience**  
**Cutting-Edge Performance Vinyl**  
**Versatile Style Integration**



## Cutting-Edge Vinyl Technology

Our innovative formula and performance co-extruded frames maintain the perfect balance between your desired luxury look and durability in the hottest of climates.

### Extreme Heat Resistance

#### ANTI-WARPING, ANTI-SHRINKING

Engineered to withstand extreme heat with no structural damage or deformation to your windows and doors. Tested to endure temperatures up to 200°F, Zenith Series frames resist warping and shrinking. Long-lasting performance is guaranteed even in the most demanding environments.

## Matte Black Color Performance Vinyl

#### ADVANCED COLOR-FADE RESISTANCE

Full-color penetration and vinyl composition maintains long-lasting black finish where traditional vinyl would fail and fade over time.

#### CAPSTOCK PROTECTION

Structural and aesthetic protection from durable co-extruded layer.

### Premium Sound Insulation

The superior construction and materials used effectively reduce external noise, creating a quieter and more peaceful indoor environment. The Zenith Series offers peak resistance to sound pollution.

### Highest Energy Efficiency Standards

Manufactured for the best climate control and energy savings, the Zenith Series has passed ASTM International and AAMA energy standards, as well as the strictest energy efficiency guideline in the U.S.: California's Title 24.



## Elegant Design for Versatile Style Integration

Achieve your dream vision with the luxury design of the Zenith Series Windows & Doors.

Meticulously crafted for maximum compatibility with the latest architectural trends without sacrificing performance or aesthetics. Innovative engineering meets the demands of diverse climate regions and project requirements, granting higher creative freedom than ever before. It's the perfect way to add luxury to any modern space.

### ■ Windows



PICTURE



SINGLE HUNG



DOUBLE HUNG



CASEMENT



AWNING



HORIZONTAL SLIDER



CUSTOM SHAPES

### ■ Doors



SLIDING PATIO

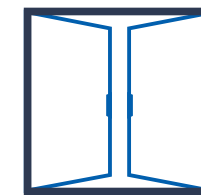

FRENCH DOOR

## Experience the view, not the outside heat.

Zenith Series windows allow you to maximize natural light in the hottest climates while still staying cool. Rest easy knowing your windows are built to withstand extreme heat without warping or shrinking.

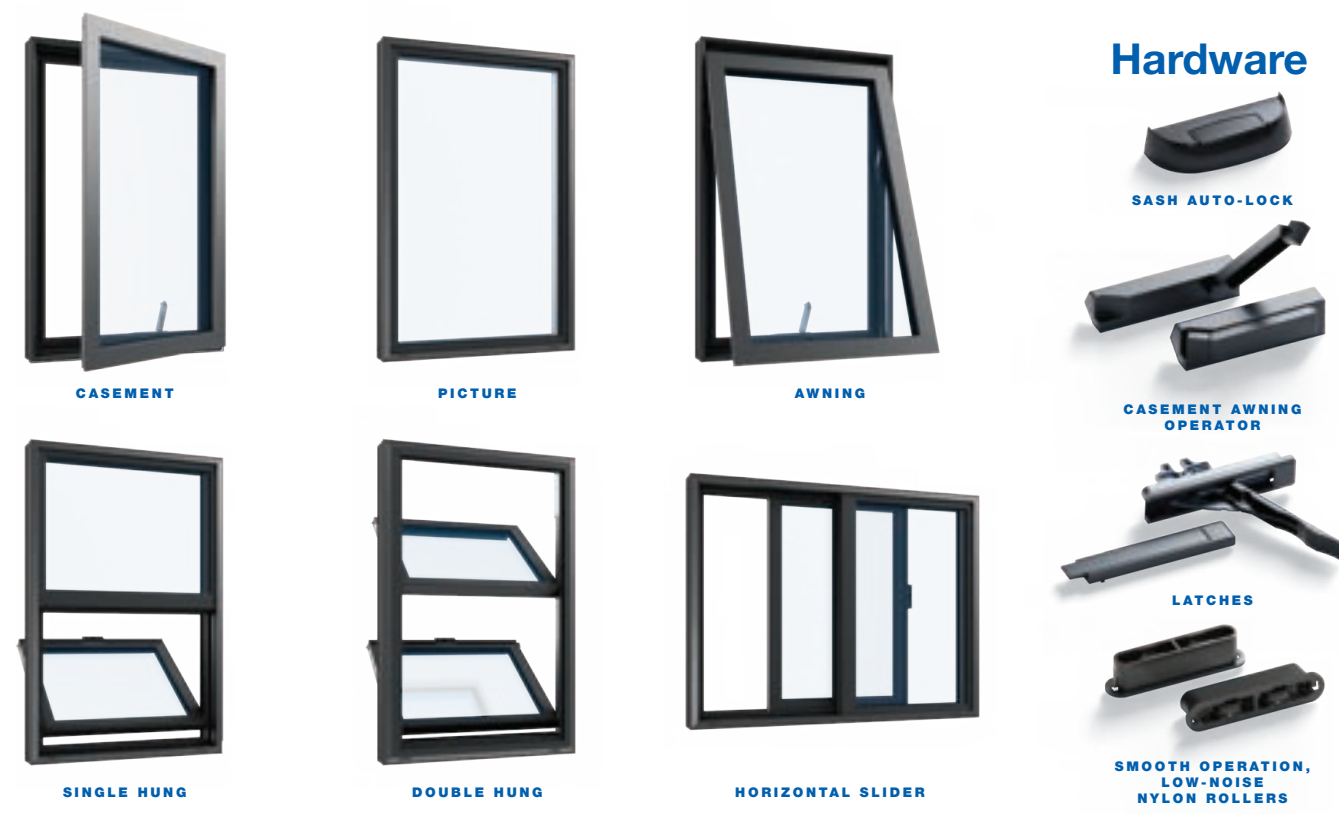

## Framing Details

### RETROFIT CASEMENT TRIPLE PANE

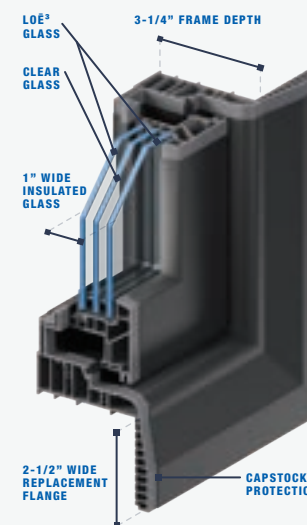

### BLOCK HORIZONTAL SLIDING DOUBLE PANE

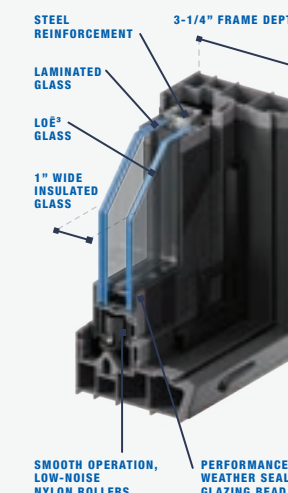

### NAIL ON 1" PICTURE DOUBLE PANE

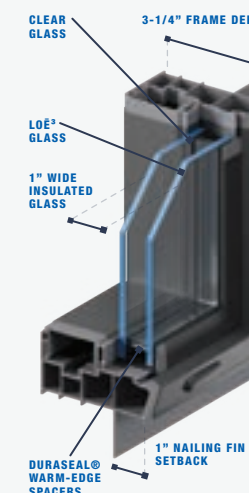

### NAIL ON 1-3/8" DOUBLE HUNG DOUBLE PANE

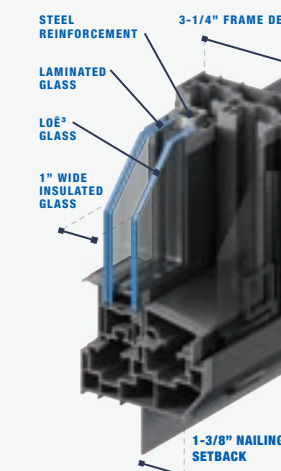

## Extend any space in full comfort.

Create elegant indoor-outdoor transition experiences with Zenith doors. Our premium materials and innovative manufacturing process keep the noise and heat out while allowing you to enjoy beautiful views and natural light.



SLIDING PATIO DOOR



FRENCH DOOR



SLIDING PATIO  
HARDWARE (KEY LOCK AVAILABLE)



FRENCH DOOR  
HARDWARE

## **■ Windows & || Doors**

### Additional Features

#### PREMIUM ENERGY EFFICIENCY STANDARD

Low-E coatings reflect sunlight to maintain comfortable indoor temperatures, while superior frame construction and spacers ensure maximum energy loss protection.

#### GLASS TEXTURES

Create privacy by customizing any space with our selection of textured glass patterns. Ask vendor for details.

#### CUSTOM GRIDS

Add an elegant element to your windows and doors with a grid design. Inside glass grids allow for easy maintenance. Ask vendor for details.

# Zenith Series

PREMIUMWINDOWS.COM

Elevated Luxury Experience  
Cutting-Edge Performance Vinyl  
Versatile Style Integration

## Windows



PICTURE



SINGLE HUNG



DOUBLE HUNG



CASEMENT



AWNING



HORIZONTAL SLIDER



CUSTOM SHAPES

## Doors



SLIDING PATIO



FRENCH DOOR



**Premium**  
WINDOWS & DOORS